



Explosion Proof Ventilator

Widely used in many spots with inflammable and explosive gas for ventilation



PRODUCT DESCRIPTION

- Composed of explosive proof engine, 7 aluminum blades, copper inner barrel and cylinder.
- Impeller: integrated aluminum alloy die-casting
- Cylinder: made of high quality hot dipping steel plate, it is of high intensity.
- Aluminum blades and copper inner barrel
- By separating the steel cylinder and aluminum blades, the copper inner barrel can effectively avoid of generating spark during start and working of the ventilator, and to assure the safety of the working space.
- Engine: has a very dependable performance, low energy consumption, long performance life, wiring steel piping.

Explosive-proof Portable Ventilator Technical Data Sheet

Model	Size (mm)	Voltage (V~)	Phase	Frequency (Hz)	Power (W)	R.P.M (r/min)	Air volume (m ³ /min)	Pressure (Pa)	NoisedB (A)	Net weight (Kg)
SHT-20	200/10 "	220	1	50	150	2800	25	245	79	13.5
SHT-30	300/12 "	220	1	50	520	2800	60	343	92	17.5

APPLICATION

200mm, 300mm, 110V,220V are available. It is appropriate for the cleaning of large container and oil house of the food and chemical industry when combined with the explosive proof flexible duct,

It has been widely used in many spots with inflammable and explosive gas for ventilation, such as chemical industry, metallurgy, spinning, petroleum, oil ship and mine.





Electrical Apparatus for Explosive Atmospheres
CERTIFICATE OF CONFORMITY

Serial No: CNE_x11.1590

Manufacturer FOSHAN GAOMING DAFENG VENTILATION EQUIPMENT FACTORY
(No.1 Xingjiao Rd., Sanzhou Cangjiang Industrial Zone, Gaoming Foshan Guangdong P.R.C)

Product Single phase explosive proof axial-flow exhaust fan

Item 300mm 220V 520W

Marking Exd II BT4

Standard Q/HX 2-2010

Drawing No. 60T.d.A40.000.0c

The drawing, technical documents and samples are verified and certified according to standard(s) for safety as follows:

GB3836.1-2000—Electrical equipment using in the Explosive gas atmospheres Part 1: General requirements

GB3836.2-2000—Electrical apparatus for explosive gas atmospheres Part 2: Flameproof enclosure “d”

Notes: 1. Representative products
200mm 220V 150W
YTA_d3-60 380V 600W
YTA_d3-60 220V 650W Exd II BT4

Valid date FROM 2011-6-29 TO 2016-6-28

Director 

CHINA NATIONAL QUALITY SUPERVISION AND TEST CENTER
FOR EXPLOSION PROTECTION ELECTRICAL PRODUCTS

Issuing date 2011-6-29

Note: This Certificate is only valid for the products which identify with the sample(s) tested and verified.

Holder(s) of this certificate have the responsibility to ensure the products complying with relation standard(s).

Address: Nanyang, Henan, P.R.C

Post code: 473008

Tel: 0377-63258564, 63258555

Fax:0377-63208174,63225471

FOSHAN GAOMING DAFENG VENTILATION EQUIPMENT FACTORY

佛山市高明区大风通风设备厂

INSPECTION REPORT

产品出厂检验单

Name of material: PVC Antistatic Fabric

检验项目 test items	检测值 the measured figure	判定 determinant
GSM weight 克重	470±20 (g/sqm)	合格 qualified
Thickness of fabric 织布厚度	0.40mm	合格 qualified
Tensile strength warp 拉伸强度 (经)	300 (N/5cm)	合格 qualified
Tensile strength weft 拉伸强度 (纬)	350(N/5cm)	合格 qualified
Tear strength warp 拉断强度 (经)	20N	合格 qualified
Tear strength weft 拉断强度 (纬)	40N	合格 qualified
Fire-resistant coefficient 阻燃系数	Fire-resistant B grade	合格 qualified
Oxygen index 含氧指数	≥30	合格 qualified
Surface resistance 表面电阻	≤2×10 ⁴ Ω	合格 qualified
Range of Temperature 适用温度范围	-15degrees to +80degrees	合格 qualified

抽检地点 Spot checking place: 仓库 warehouse

检验员 Checker: 李盛坚

佛山市高明区大风通风设备厂 (质检部)

ISSUED BY: FOSHAN GAOMING DAFENG VENTILATION EQUIPMENT FACTORY

(department of quality control)

2013年3月1日

EXPLOSIVE PROOF PORTABLE VENTILATOR

Description	Item No.	Size(Diameter)	V~	Power (W)	r.p.m (r/min)	Capacity (m ³ /min)	GW (kgs)	Meas (cm)
<p>1.composed of explosive proof engine, aluminum blades, copper inner barrel and cylinder.</p> <p>2.Impeller: integrated aluminum alloy die-casting</p> <p>3.Cylinder: made of high quality hot dipping steel plate, it is of high indensity.</p> <p>4.aluminum blades and copper inner barrel</p> <p>5. By separating the steel Cylinder and aluminum blades, the copper inner barrel can effectively avoid of generating spark during start and working of the ventilator, and to assure the safety of the working space.</p> <p>6.engine: has a very dependable performance, low energy consumption, long</p>	SHT-20-1	200mm(ID)/8"	220V/50Hz	150	2800	25	15	42*36*34
	SHT-20-2	200mm(ID)/8"	110V/60Hz	150	3400	35	15	42*36*34
	SHT-30-1	300mm(ID)/12"	220V/50Hz	520	2800	60	19	49*42*42.5
	SHT-30-2	300mm(ID)/12"	110V/60Hz	520	3400	70	19	49*42*42.5

VERIFICATION OF EMC & LVD COMPLIANCE

OMA Testing
Certification

Certificate No. OMA/121315270

Applicant : Foshan NuoWei Ventilation Co., Ltd.

Address of Applicant : NO.639, SHANG DONG QI SHAN DEVELOPMENT
AREAS NAN HAI JIU JIANG DISTRICT, FOSHAN CITY
GUANGDONG, CHINA

Product Description : PORTABLE VENTILATOR

Type and Model : SHT-20, SHT-25, SHT-30, SHT-35, SHT-40,
SHT-45, SHT-50, SHT-60, SW-10

Technical Construction File : SCC(12)-587-2-10-EMC

Referenced No./Rev : SCC(12)-587-2-10-LVD

Codes/Standards Applied : EN 61000-6-1:2007, EN 61000-6-3:2007+A1:2011
EN 61000-3-2:2006+A2:2009, EN 61000-3-3:2008
EN 60204-1:2006+A1:2009+AC:2010

Date of Issuance : Dec.06,2012

Remarks : This Certificate Is Only Valid For The Equipment And Configuration
Described, And In Conjunction With The Test Data Detailed Above.

Conclusion of Assessment :

We Hereby Confirm That The Technical Construction File And Manufacturing,
Inspection And Testing Processes For Above-Mentioned Equipment Comply With The
Essential Safety Requirements Of EU Electromagnetic Compatibility 2004/108/EC
& 2006/95/EC Low Voltage Directive Applied Codes And Standards.

Chief Assessor:



Deu Technology Testing Co., Ltd
ISO/IEC17025:2005 Laboratory Accreditation
info@omauk.org



hot-dip
galvanized
sheet

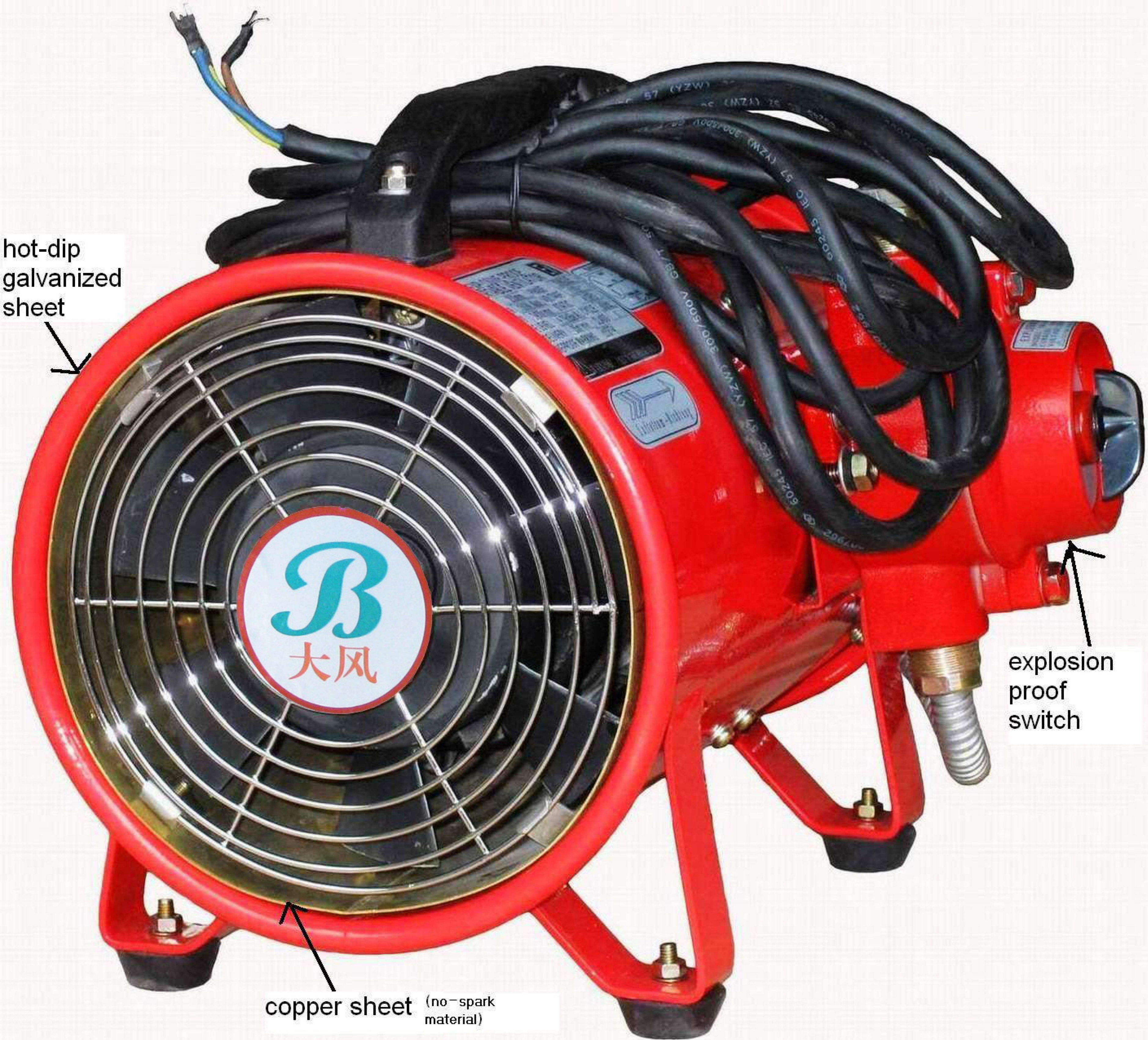

explosion
proof
switch

copper sheet (no-spark
material)

A Circuit Diagram

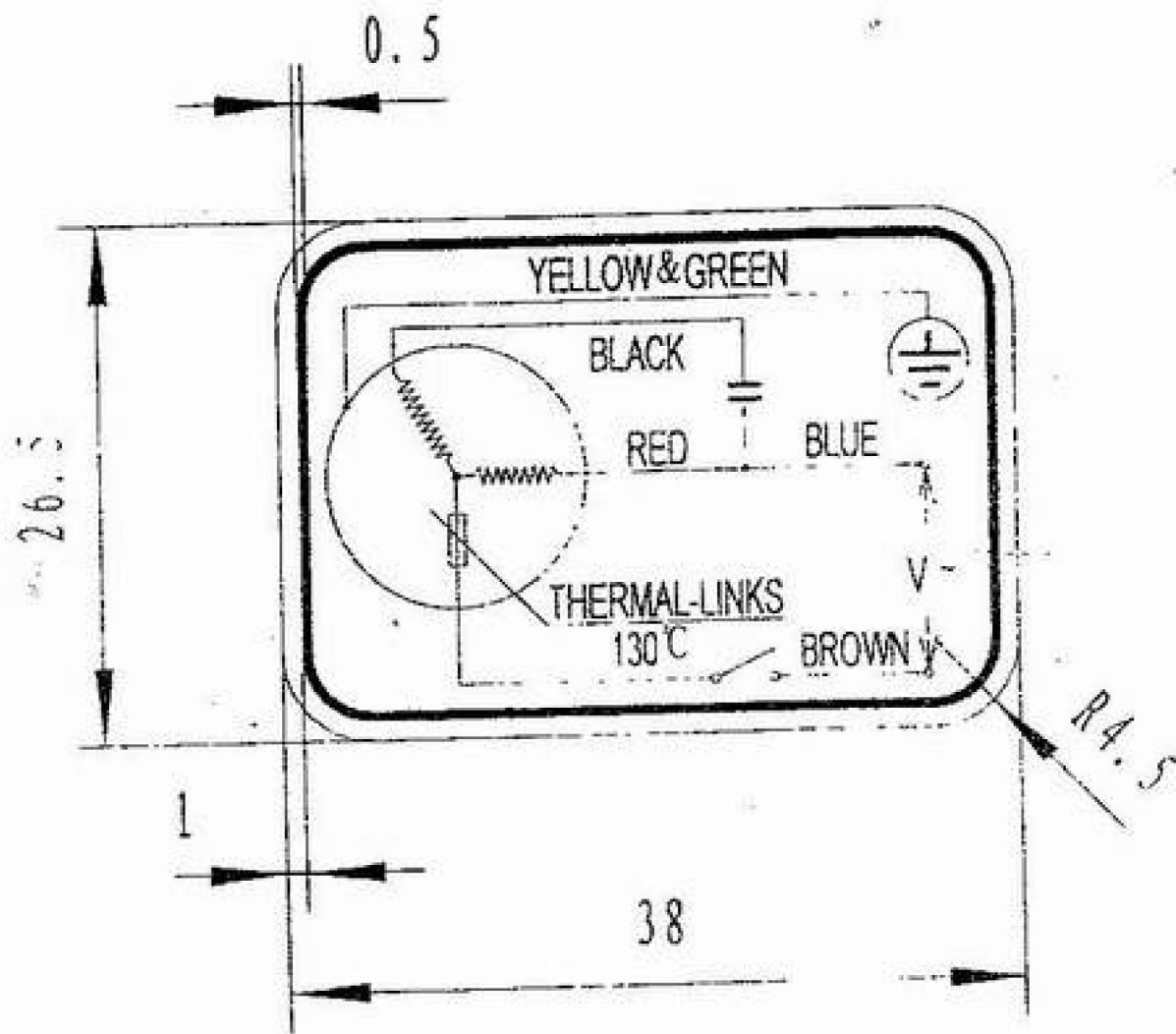

Assembling Drawing .

AIR-FLOW 

358

PORTABLE VENTILATOR

$\phi 11 \pm 1$

CABLE

FLAMEPROOF JOINT

SEALING RING

BOLT

MOTOR

SAFETY GUARD

BLADE

CYLINDER

CABLE

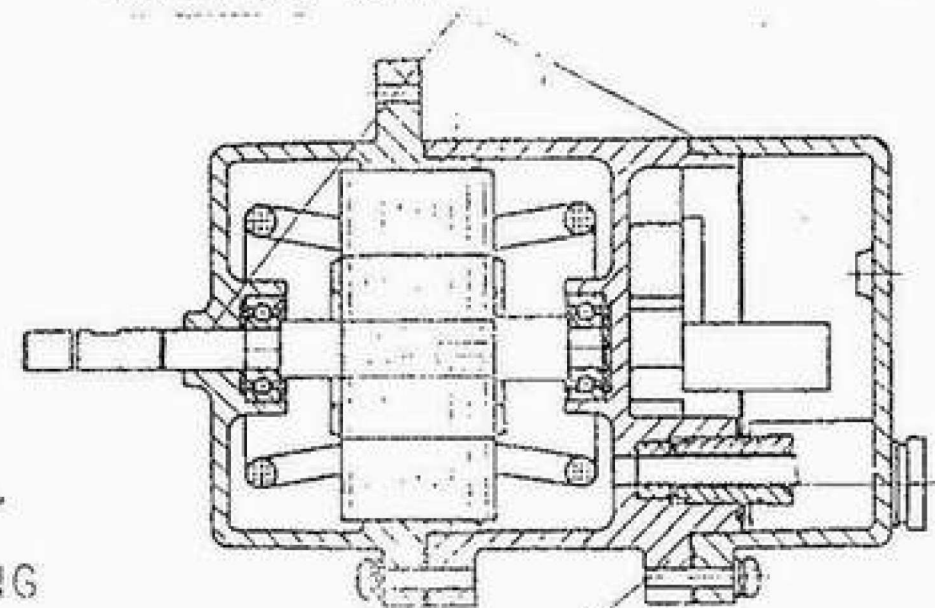
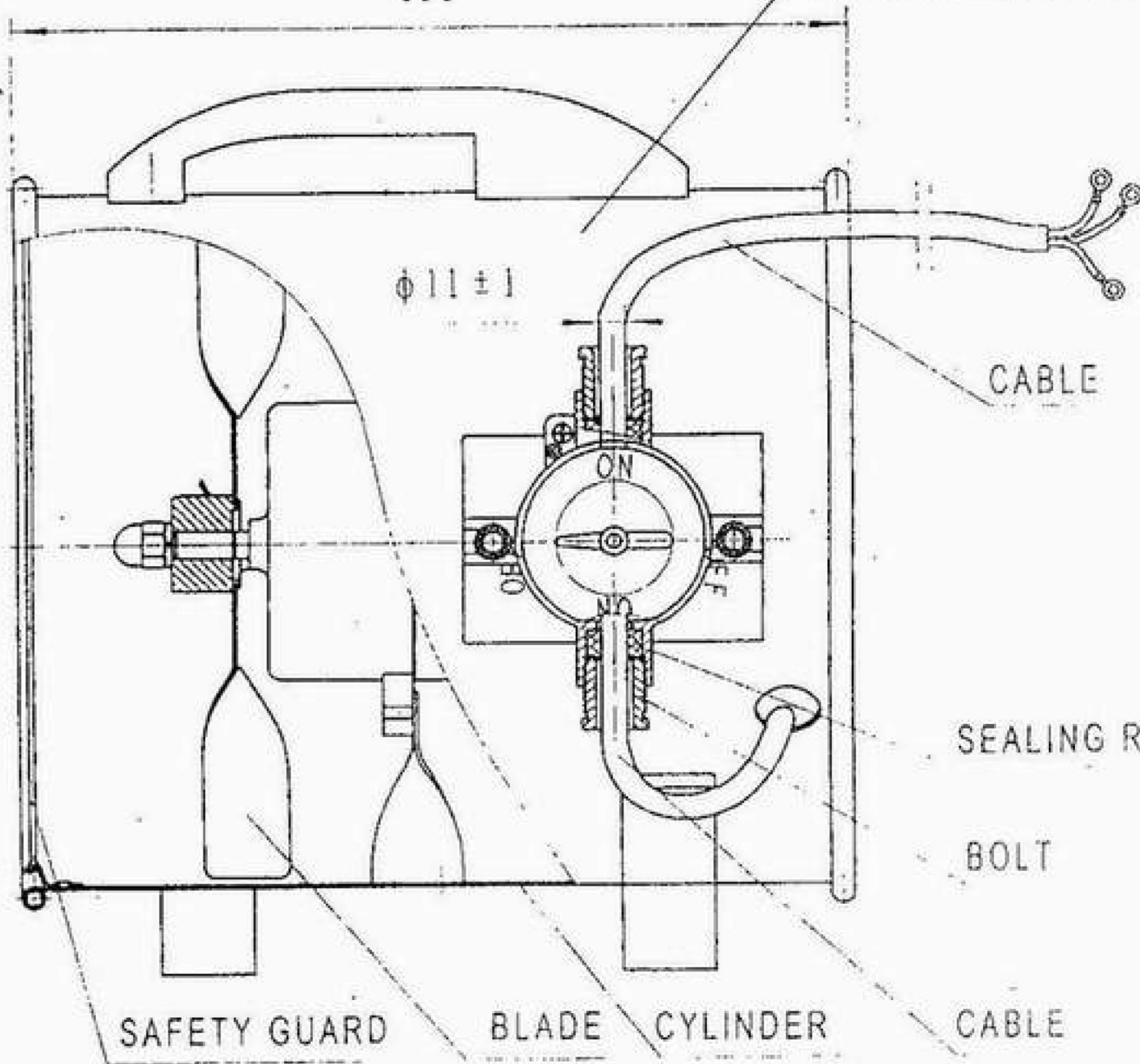

Components Drawing

FLAMEPROOF JOINT

MOTOR

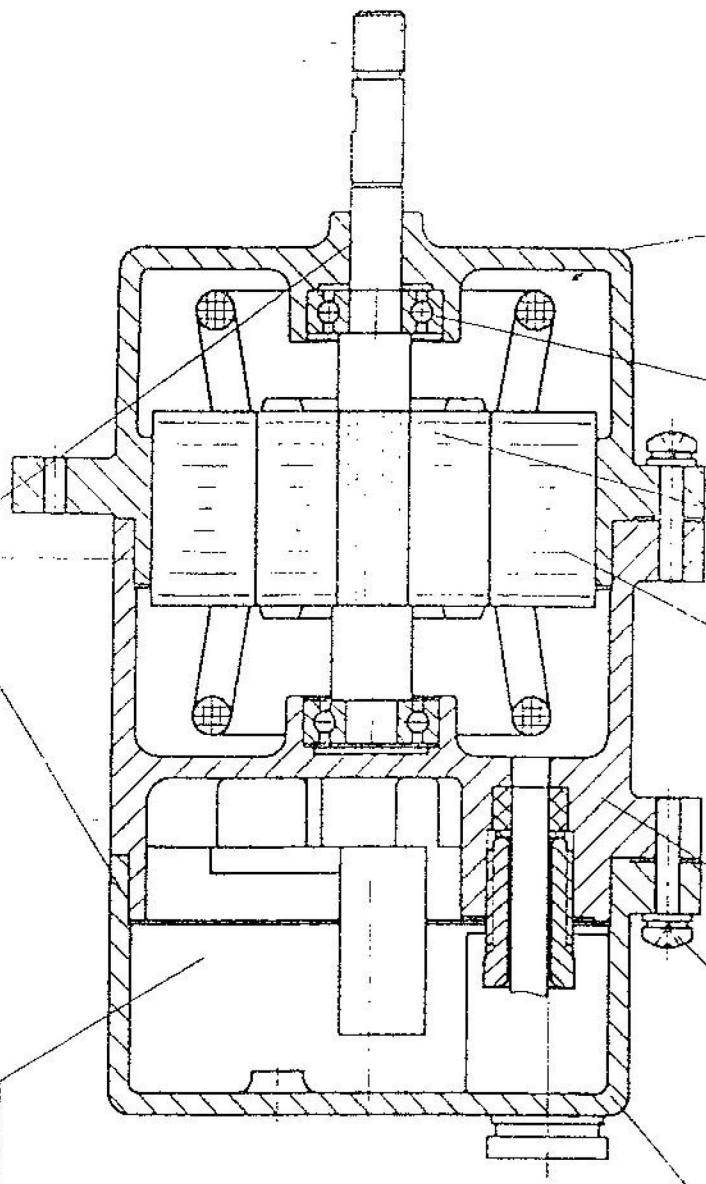

Back Cover Screw

Back Cap

Stators/Rotor

Bearing

Front Cover

EXPLOSIVE-PROOF VENTILATOR OPERATION INSTRUCTION

A. Marked "d II BT4" indicates that "d" for explosive-proof. "II" for factory use explosive-proof appliance. "B" for explosive gas B class. "T4" for The temperature of medium should not be over 135 °C). The Unit is suitable to the place where the spontaneous combustion temperature of explosive mixed-gas should be over 135 °C, such as extraction and refinement of petroleum, making of various kinds of benzene, alcohol and medicine, painting, rubber producing and so on, related factory, workshop, warehouse for ventilating.

B. Use condition

1. Altitude not exceed than 1000m.
2. House temperature not exceed than -20 °C to + 40 °C.
3. Relative humidity not exceed 90% (25 °C).
4. The places of the spontaneous combustion temperature should be over 135 °C.

C. Caution

1. Before using, turn blades with hand, to be sure that the distance between blades and grill of frame must be uniform without collision.
2. Voltage and frequency should tally with those marked on the nameplate.
3. When heavy vibration of blades and abnormal noise occur during operation, cut off electricity supply immediately and look for cause.
4. Must be protected the power switch of explosive-proof cover face from collision.
5. Check the unit once a year, replace lubricant in gear box.

